

구르미

수유시장 공유형 카트서비스

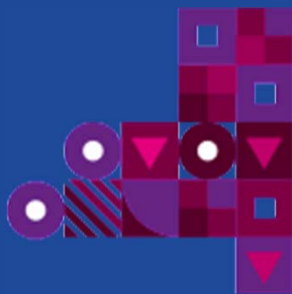
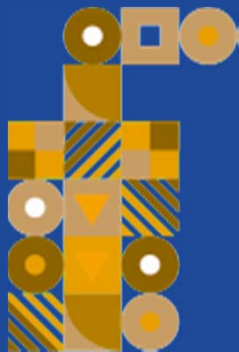

국민대학교
양은수, 김길현

01 아이디어 기획 및 목적

01-1. 개발동기



01 아이디어 기획 및 목적

01-1. 개발동기



장바구니를 **땅바닥**에 두는 모습



촉촉한 바닥의 모습



01 아이디어 기획 및 목적

01-1. 개발동기



봉투를 **여러개** 들고 가는 모습

01 아이디어 기획 및 목적

01-1. 개발동기

봉투를 한번에 들고 다닐 수 있고
좁은시장길에 맞는 **작은크기**의
카트가 필요하다!



01 아이디어 기획 및 목적

01-1. 개발동기 ... 수유시장 서비스 추적조사



PERSONA

- 40대 중년 여성
- 직업: 초등학교 교사
- 가족관계: 남편, 고2 아들
- 성격: 친절하지만, 강단있는 성격
- 특징: 남편과 맛별이를 하며 고2 (곧 수험생) 인 아들을 잘 챙겨주지 못하는 것이 항상 마음에 걸림. 마르고 밥을 잘 챙겨먹지 않는 아들을 위해 항상 시장에 들러 신선한 재료로 다양한 요리를 해주려고 노력함.
개인 자가용이 없어 **항상 버스로 출퇴근 하며,**



퇴근길 시장에 들어서 찬거리를 사감

01 아이디어 기획 및 목적

01-1. 개발동기 ... 수유시장 서비스 추적조사



무거운 짐을 들고 가는 모습

01 아이디어 기획 및 목적

01-1. 개발동기

무거운 짐을 들어줄
카트가 필요하다!



01 아이디어 기획 및 목적

01-2. 타겟소비자

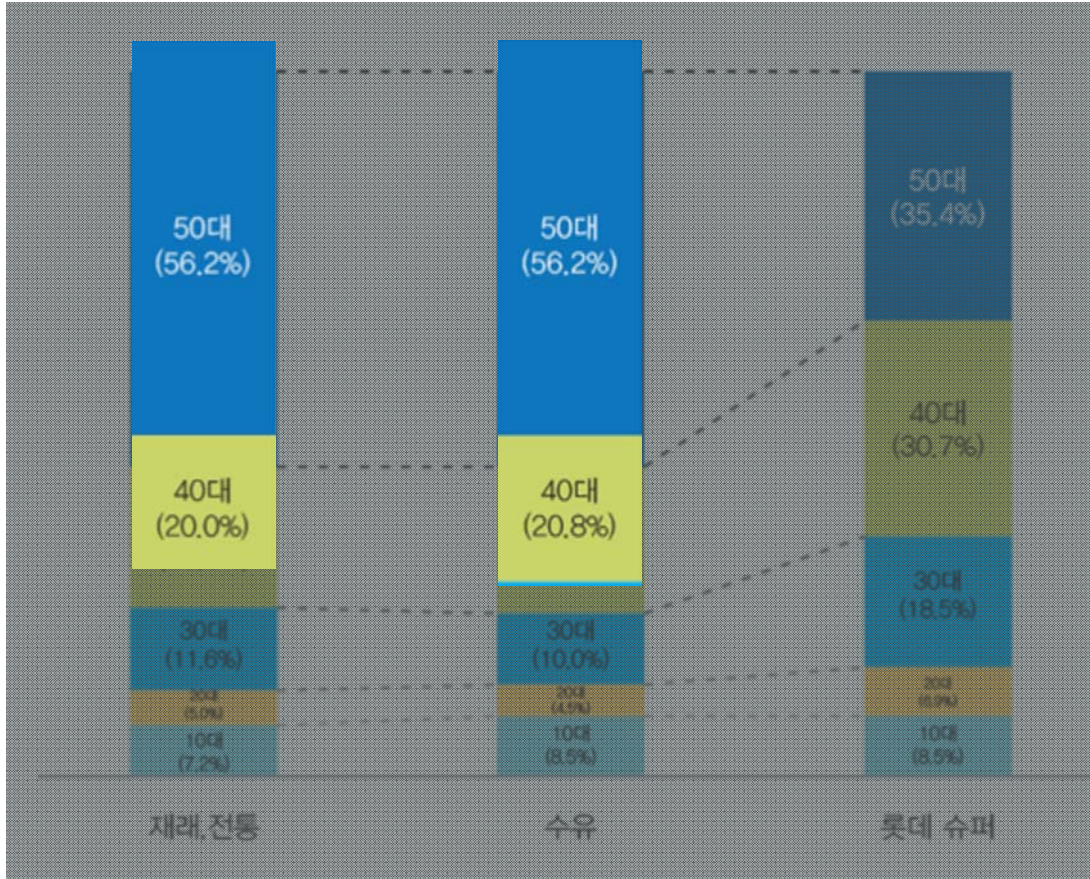

수유마을시장의 80%고객이
40세 이상

무거운 짐을 들기 어려운
40~50대 주부
의 불편함을 덜어주자!

01 아이디어 기획 및 목적

01-3. 목적



카트공유서비스

구르미를 통해 사람들이 시장에
가볍게 와서 가볍게 갈 수 있게 한다!

02 아이디어 소개

02-1. 서비스소개

회원가입 후 보증금
약 50,000 ₩
탈퇴하면 환급해준다.



소액의
이용료

자전거 공유서비스
모바이크

02 아이디어 소개

02-1. 서비스소개

회원가입 시
보증금결제
탈퇴시 환급해준다.



3시간이상 미반납시
보증금차감

카트 공유서비스
구르미

02 아이디어 소개

02-1. 서비스소개

회원가입



카트대여



카트반납



홈페이지나 APP에서
회원가입과 **카드를 등록**한다.
카드등록하면서 **보증금결제**한다.



QR코드나 **등록한 카드태깅**해서
대여소에서 카트를 대여한다.

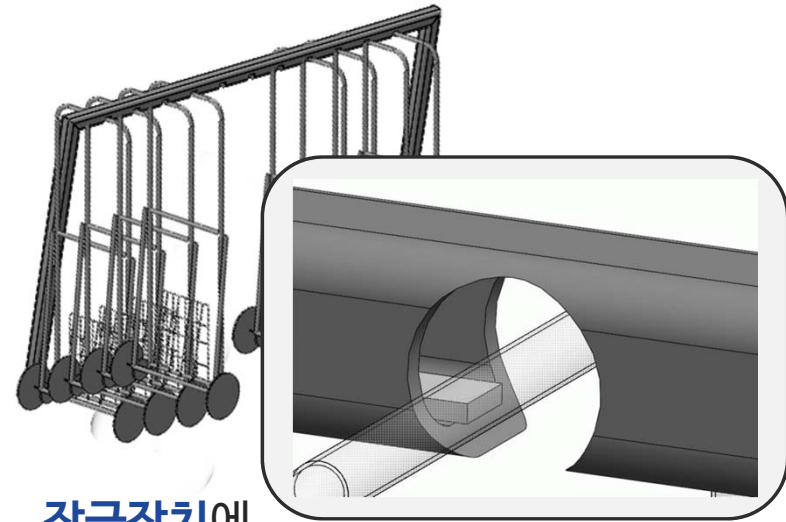

잠금장치에
연결한다.

02 아이디어 소개

02-1. 서비스소개



▲ 처음화면



▲ 카드등록

02 아이디어 소개

02-1. 서비스소개



▲ QR코드인식

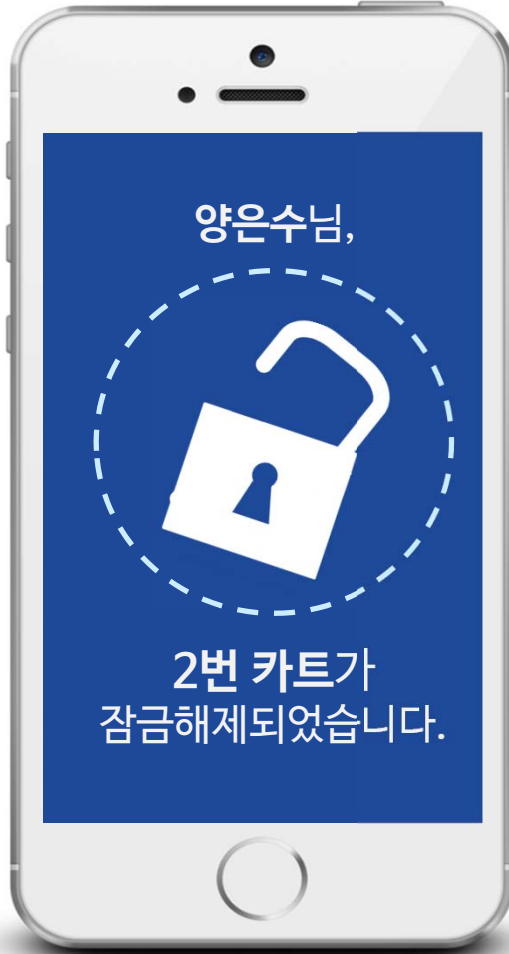

▲ 카트대여



▲ 카트반납

02 아이디어소개

02-2. 카트/대여소디자인



시장의 좁은 길에
너무 큰 대형카트

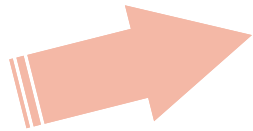

시장의 좁은 길에 맞춘
접이식·소형카트

02 아이디어소개

02-2. 카트/대여소디자인

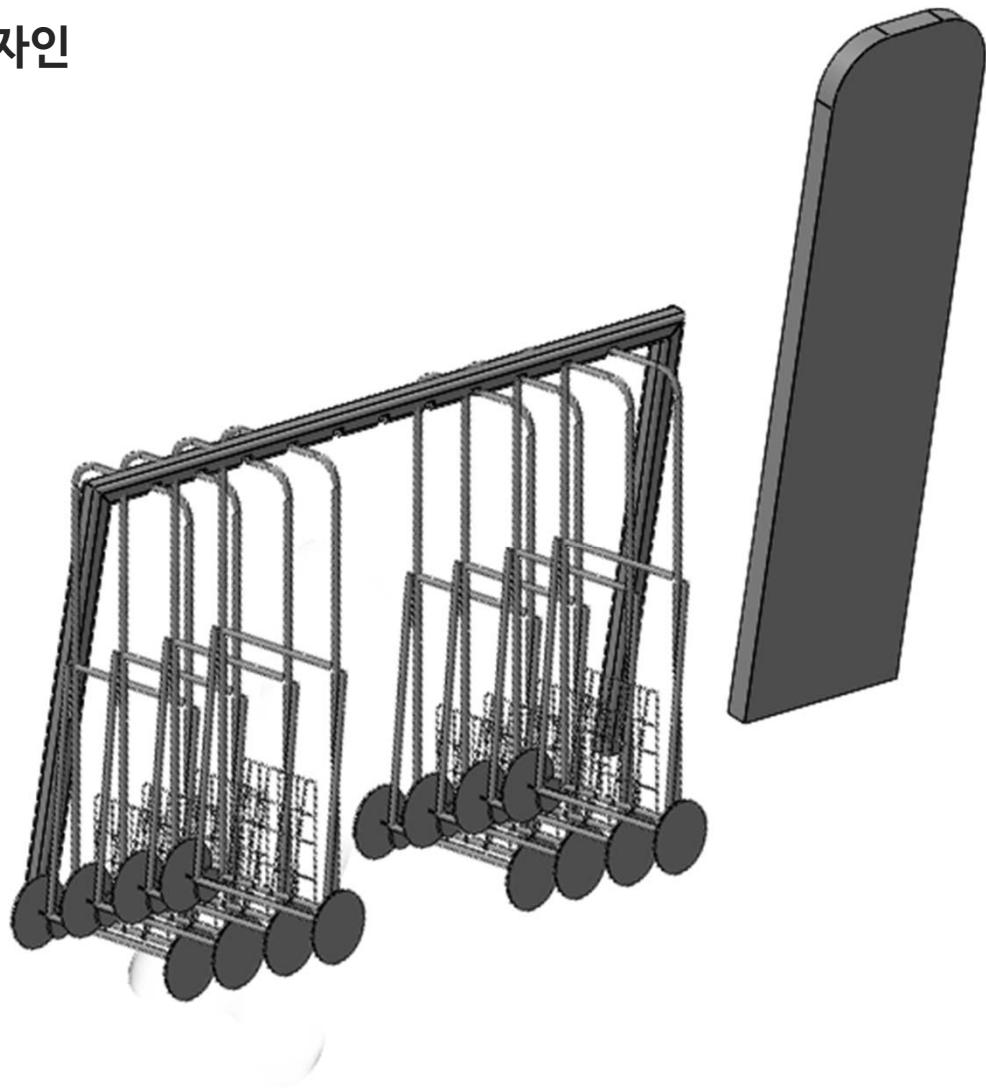

02 아이디어소개

02-2 카트/대여수디자인

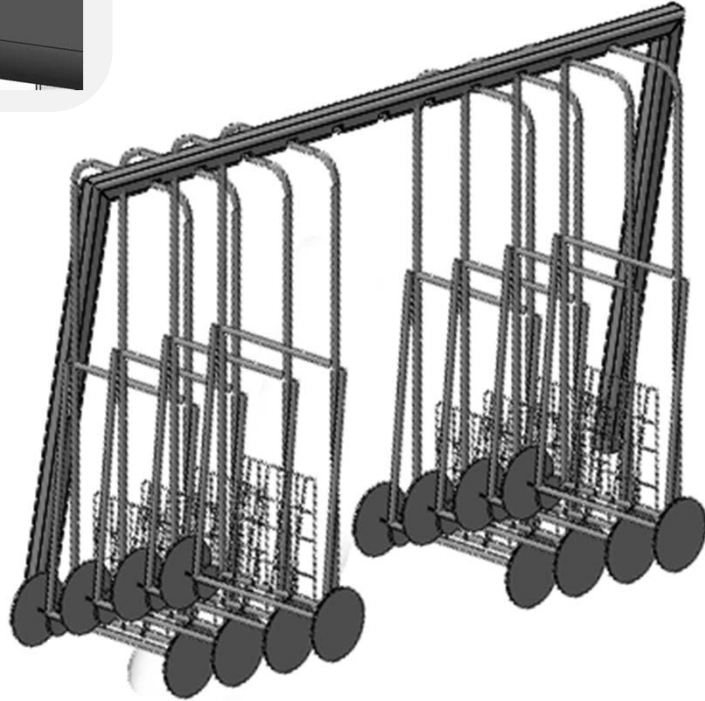
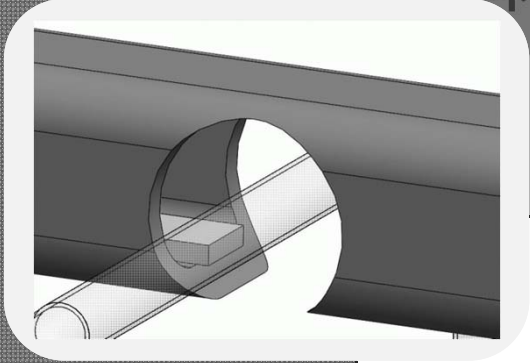

카트잠금장치

QR코드와 카드인식기

두가지
대여방식

02 아이디어소개

02-2. 카트/대여소디자인



대여안내판

장바구니자판기

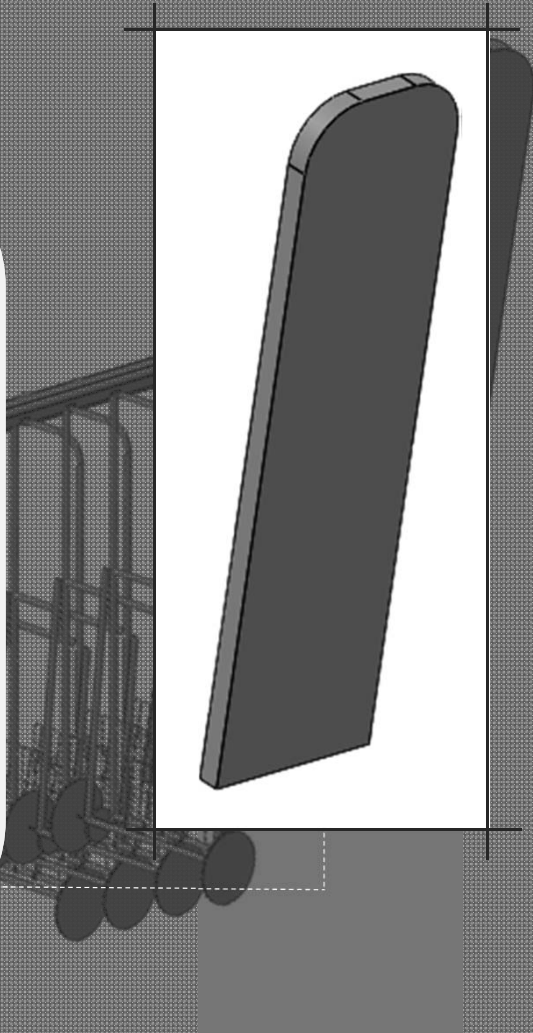

여러개의 봉투를
한 번에
들고 갈 수 있게

칸막이
로 수납공간확보

03 성장가능성

03-1. 부가기능... 배달



무인배달보관함
을 활용한 배달서비스

1

무인보관함에
장본 것을 넣는다.

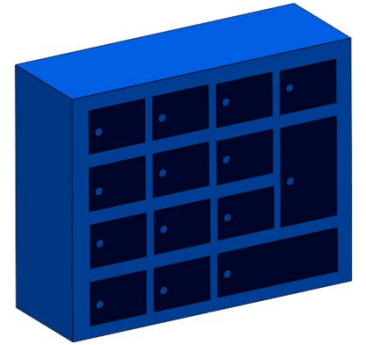

2

정해진 시간마다 배송
Ex) 2시, 4시, 6시



3

집에서 장본 것을 받는다.



03 성장가능성

03-2. 확장가능성

수유시장의
브랜드화

상인들의 온라인 직거래
로 확장가능성

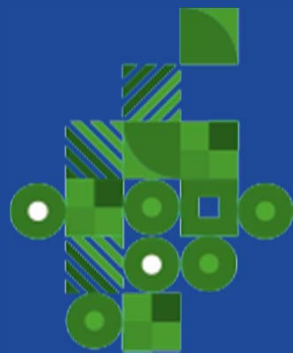
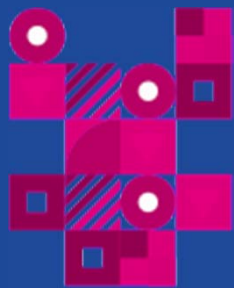

감사합니다.

